

Mountain Trike

Owner's Manual



Riding over difficult terrain can be challenging, please take all necessary care, It is important that you read this manual before riding your new Mountain Trike.

Mountain Trike Owner's Manual

1st Edition 2011

This manual is designed to meet EN Standards 12182, 12183, 14971

IMPORTANT:

This owner's manual contains important safety, performance and service information. Please read it before you take the first ride on your new Mountain Trike and keep it for reference.

Additional safety, performance and service information for specific components such as the suspension on your Mountain Trike may also be available. Make sure that your dealer has given you all the manufacturers' literature that was included with your Mountain Trike; a complete list can be found on page 9. In case of a conflict between the instructions in this manual and information provided by a component manufacturer, always follow the component manufacturer's instructions.

If you have any questions or do not understand something, take responsibility for your safety and consult with your dealer.

NOTE:

This manual is not intended as a comprehensive use, service, repair or maintenance manual. Please see your Mountain Trike dealer for all service, repairs or maintenance.

Mountain Trike Frame Number	_____
Mountain Trike Order Number	_____
Date of Purchase	_____

Introduction

Congratulations! You now possess one of the finest all terrain wheelchairs in the world. The following pages will provide you with the information you need to properly use, adjust and maintain your new Mountain Trike, so you can get the most out of every ride.

It is essential that you read this owner's manual thoroughly before riding your Mountain Trike, we know you're anxious to get riding, but it will only take a few minutes, and then you can unleash the full potential of your Mountain Trike.

Please pay special attention to the safety information and cautions shown throughout this owner's manual.

If you encounter any issues with your Mountain Trike that aren't covered in this manual, please contact your nearest Authorized Mountain Trike Dealer. As your number one resource, your Mountain Trike dealer can answer questions, perform required maintenance and recommend the best equipment to complement your ride.

Thank you for buying a Mountain Trike!

Enjoy the ride!

All diagrams included in this manual are based on a right hand steering Mountain Trike, although left handed steering options are also available at your Mountain Trike dealer.

Table of Contents

Introduction	4
A word about warnings, accidents and safety	6
Think Safety	7
A Special Note for Parents	7
Your Mountain Trike	8
1.0 Setting up your Mountain Trike	8
1.1 Intended Operator	8
Frame Size	9
Arm Reach	9
1.2 Assembly and Disassembly for Storage	10
Seat Folding	11
Folding the Rear Wheel	11
Drive Module Removal	13
Removal of Rear Wheel Steering Cable Attachment	15
Footrest and Anti-tip Wheel Adjustment	15
2.0 Riding instructions	16
2.1 Pre-Ride Mechanical Safety Checks	16
Suspension	17
Tyre Pressures	17
2.2 Transferring in and out	17
2.3 How to Engage / Disengage Drive	19
2.4 Forward Drive	20
2.5 Reverse Drive	20
2.6 Steering	21
2.7 Braking	22
Anti-Tip Wheels	22
2.8 Hill and Kerb Climbing	22
2.9 Descending Slopes	23
3.0 The Safety Bit	24
3.1 Riding safely about town	24
3.2 Riding safely Off Road	25
3.3 Wet Weather Riding	26
3.4 Night Riding	26
3.5 Extreme riding	26
3.6 Adding Accessories and Changing Components	27
4.0 Service	28
4.1 Looking After Your Mountain Trike	28
Drive	29
Brakes	30
Steering	30
Frame and Seat	31
4.2 Maintenance Schedule	32
4.3 Bedding in Period	32
5.0 Warranty	33



A word about warnings, accidents and safety

The Mountain Trike is designed to be used for transportation, recreation and exercise. Riding it can be dangerous, especially if you try to ride beyond the limits of your ability. The skill of riders can vary greatly, do not ride in a manner that exceeds your ability.

Mountain Trike riding involves risk of injury and damage. By choosing to ride a Mountain Trike, you assume the responsibility for that risk, so you need to know and to practice the rules of safe and responsible riding and of proper use and maintenance. Proper use and maintenance of your Mountain Trike reduces risk of injury.

If you crash or apply force that is higher than the limits of your Mountain Trike, you are very likely to cause damage to it or its parts. If your Mountain Trike has been damaged and you crash or load it again later, this additional impact or loading can cause a failure at a much lower load.

This Manual contains many "Warnings" and "Cautions" concerning the consequences of failure to maintain or inspect your Mountain Trike and of failure to follow safe riding practices.

- The combination of the safety alert symbol  and the word **WARNING** indicates a potentially hazardous situation which, if not avoided, could result in serious injury or death.
- The combination of the safety alert symbol  and the word **CAUTION** indicates a potentially hazardous situation which, if not avoided, may result in minor or moderate injury, or is an alert against unsafe practices.
- The word **CAUTION** used *without* the safety alert symbol indicates a situation which, if not avoided, could result in serious damage to the Mountain Trike or the voiding of your warranty.

Many of the Warnings and Cautions say "you may lose control and fall". Because any fall can result in serious injury or even death, we do not always repeat the warning of possible injury or death.

Because it is impossible to anticipate every situation or condition which can occur while riding, this Manual makes no representation about the safe use of the Mountain Trike under all conditions. There are risks associated with the use of any Mountain Trike, which cannot be predicted or avoided, and which are the sole responsibility of the rider.

Think Safety

Always think about your safety and avoid dangerous situations. Make sure you read this manual before you ride. Some skilled riders may use the Mountain Trike in ways that are obviously not safe. You add to your risk when you make modifications, ride in unusual locations or ride in a high-risk manner.

A special note for parents

As a parent or guardian, you are responsible for the activities and safety of your minor child, and that includes making sure that the Mountain Trike is properly fitted to the child; that it is in good repair and safe operating condition; that you and your child have learned and understand the safe operation of the Mountain Trike. As a parent, you should read this manual, as well as review its warnings and the Mountain Trike's functions and operating procedures with your child, before letting your child ride.



WARNING - Make sure that your child always wears an approved Bicycle helmet when riding; but also make sure that your child understands that a Bicycle helmet is for Mountain Trike riding only, and must be removed when not riding. A helmet must not be worn at any time while not riding a Mountain Trike, if the helmet is caught, the wearer could choke.

Your Mountain Trike

Each Mountain Trike has its own unique identification (ID) number. This Trike ID enables you and the dealer to identify the Trike and record its history. The Trike ID can be found stamped into the frame under the seat.

Please take a moment to write down your Trike ID and Dealer's name for your own records on page 3 in this manual.

Accompanying this manual you should also have been supplied with the following:

- Shock pump
- Multi Allen key
- Splined Allen key for brakes
- Brake Instruction manual
- Shock Instruction manual

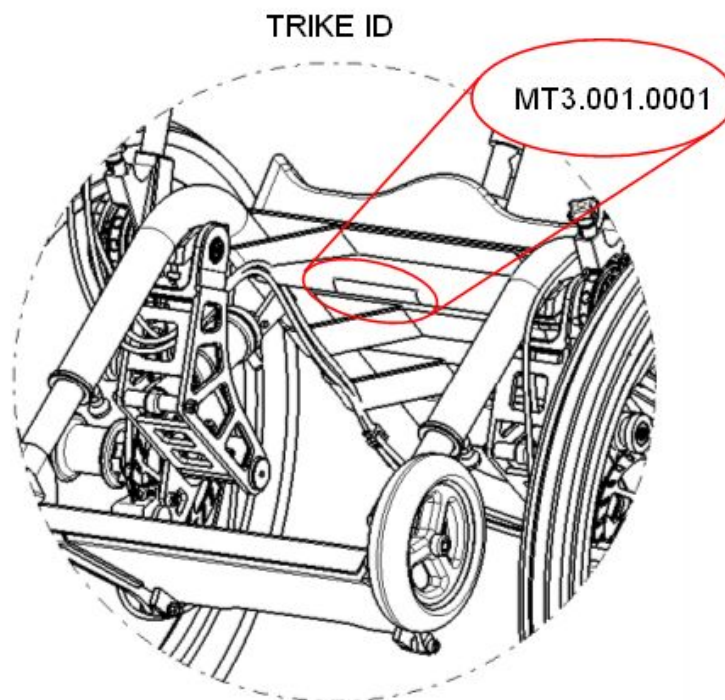

1.0 Setting up your Mountain Trike

We strongly urge you to read this Manual in its entirety before your first ride. At the very least, read and make sure that you understand each point in this section, and refer to the cited sections on any issue which you don't completely understand. Please note that not every Mountain Trike has all of the features described in this manual and the Trike pictured in the images may differ slightly to your own Trike. Ask your dealer to point out the features of your Mountain Trike.

1.1 Intended Operator

The Mountain Trike is a manual all terrain wheelchair that gives unsurpassed performance on a variety of challenging types of terrain.

In order to operate or ride the Mountain Trike safely and make best use of its features, certain levels of upper body, hand/grip strength and control are required. A reasonable amount of upper body strength is required to apply force to the propulsion levers, hand control is required to

direct the Steering Handle to manoeuvre the Mountain Trike, and finger control is required to operate the brake levers. Due to the vast range of individual abilities, it is the responsibility of the user or the user's guardian(s) to deem the rider as suitable for using the Trike.

Alternatively, if you are unsure as to whether you could use the Trike safely and effectively, your Mountain Trike dealer can assist you and make the appropriate recommendations.

Frame Size

To get the most enjoyment from riding your Mountain Trike, selecting the correct frame size adjustment is important. The Mountain Trike seat back rest has three settings, Small, Medium and Large, depending on your arm length. Your Mountain Trike Dealer will advise you on the correct seating position for you.

 **CAUTION** - Riding a Mountain Trike that does not fit you could strain muscles, cause fatigue or result in limited operation of the controls which could cause you to lose control and fall.

 **CAUTION** - The designed maximum weight of the rider is 100 kg (16 stone)

Arm Reach

The Trike uses lever mounted controls. It is important that the rider can comfortably reach the drive levers and exact the appropriate amounts of force and control to safely operate the Trike. The ability to use the braking system correctly is fundamental to safe operation. The efficiency of the lever drive is also dependent on choosing the right size with the right amount of reach. Failure to do so will result in increased levels of fatigue and poor performance. For advice on sizing and setup please contact your Mountain Trike Dealer.

Mountain Trikes have brake levers which can be adjusted for reach. If you have small hands or find it difficult to squeeze the brake levers, your dealer can adjust the reach within the range provided by the brake manufacturer.

 **WARNING** - The shorter the brake lever reach, the more critical it is to have correctly adjusted brakes so that full braking power can be applied within the available brake lever travel. If the brake lever travel is insufficient to apply full braking power, it can result in loss of control, which may result in serious injury or death.

1.2 Assembly and Disassembly for Storage

The Mountain Trike is designed in such a way that, when folded, it will fit into the back of a car for easy transport or require as little space as possible for storage. If however the space available is severely restricted, further disassembly is possible, separating simply into three distinct modules:

- Chassis Module
- Left Drive Module
- Right Drive Module
(complete with rear wheel steering cable attachment)

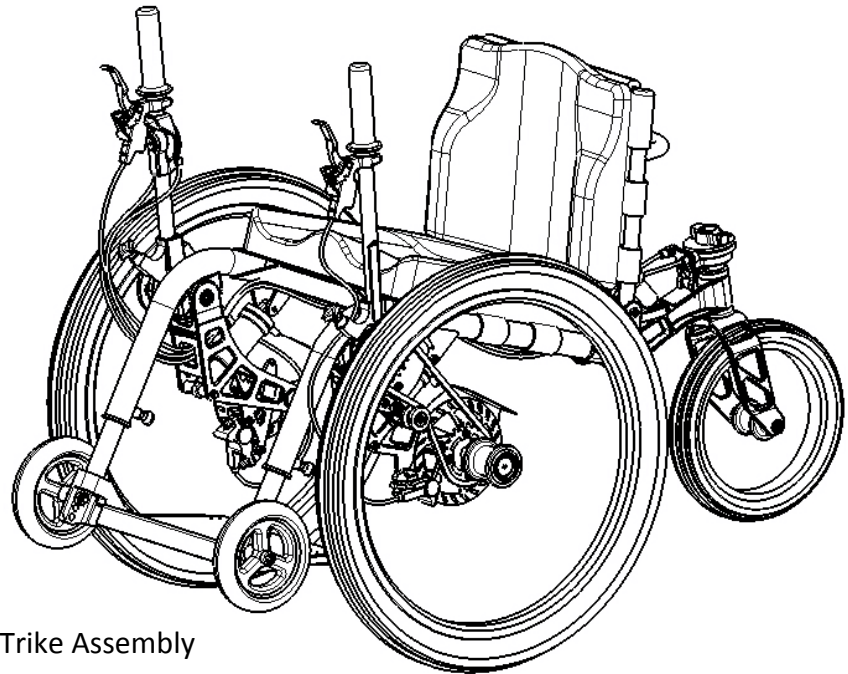

The Complete Trike Assembly

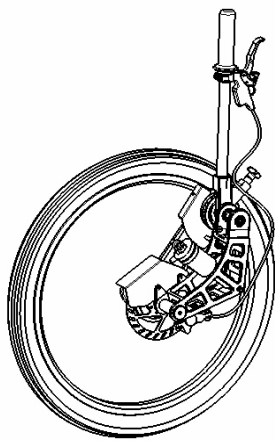

Left Drive Module

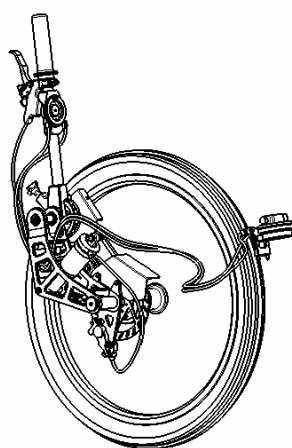

Right Drive Module (with rear wheel steering cable attachment)

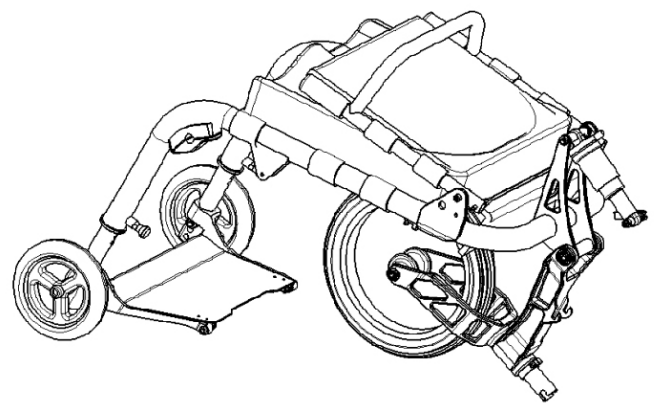

Chassis Module (with seat and rear wheel folded)



WARNING - An understanding of the differences between assembling/disassembling a Mountain Trike compared to standard wheelchairs is extremely important as failure to correctly assemble/disassemble the product could affect performance, causing the rider to lose control and fall.

Seat Folding

For efficient stowing of the Mountain Trike for transport or storage, remove the seat cushion and the seat back folds down flat against the base. To fold the seat back down, pull the cord joining the two locking pins and push seat forward. To restore the seat to its upright position, lift the seat back whilst pulling the cord, allowing the locking pins to retract. Once in the upright position, release the cord and the locking pins will spring out into the holes in the frame.

SEAT FOLDING

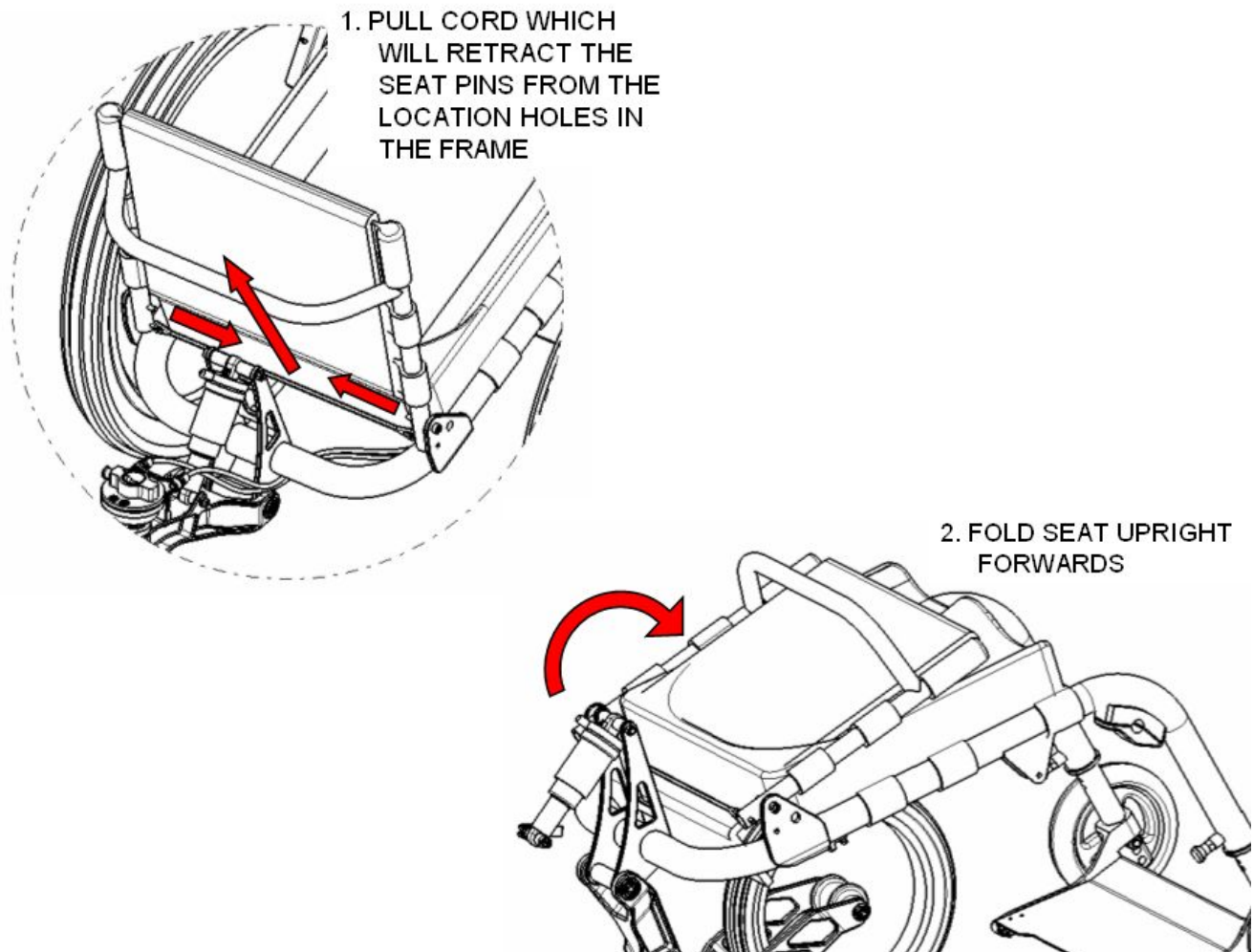

CAUTION - Ensure the locking pins are BOTH fully engaged in the holes in the frame before riding. Failure to do so could result in the seat back becoming unstable such that the user could lose control and fall.

Folding the Rear Wheel

Like the seat, the rear wheel can also be folded away. This is done by simply releasing the rear shock absorber from the rear swingarm as shown below. Once folded the rear wheel can be held in place with a Velcro strap underneath the seat base.

Using the Quick Release (QR) Lever, located at the connection between the rear shock absorber and the rear swingarm, the rear shock absorber can be separated from the Rear Swing Arm, allowing the rear wheel and swing arm to fold underneath the seat. QR levers are designed such that reasonable hand/finger strength is sufficient to provide the required compression force upon flipping the lever closed. If the lever flips with little or no resistance, then the adjusting nut will need tightening until the lever flips with enough resistance to provide adequate compression.

REAR SWINGARM FOLDING

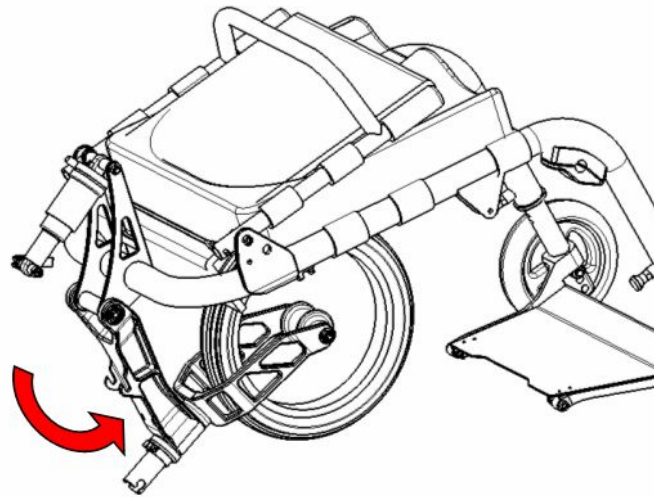

1. SLIDE SHOCK OUT OF SLOT IN SWINGARM AND FOLD UNDERNEITH FRAME
2. SECURE REAR WHEEL UNDER SEAT WITH VELCRO STRAP

2. ROTATE ADJUSTER NUT TO SET TENSION IN QR LEVER

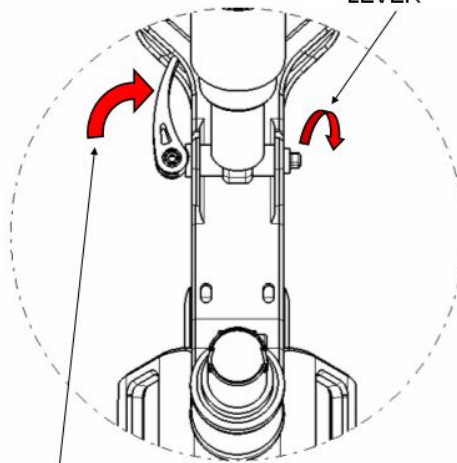

1. PUSH LEVER TO LOCK QUICK RELEASE

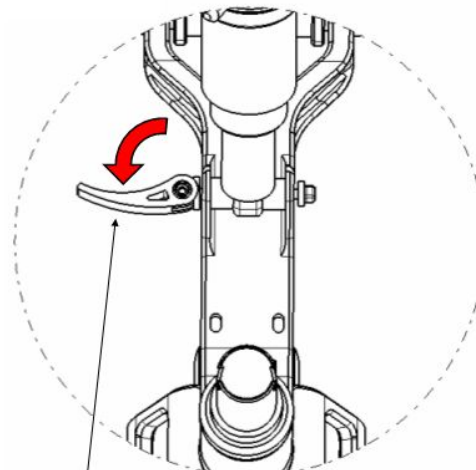

3. PULL LEVER TO UNLOCK QUICK RELEASE



WARNING - It is important that the QR levers are set to the right compression force, failure to do so could result in the rear shock becoming loose and in a worst case scenario, detaching during a ride causing the rider to lose control and fall.

⚠ WARNING - The full force of the QR cam action is needed to clamp the rear shock absorber securely. To fasten securely, hold the QR lever in the open position, as indicated in step 3 in the second diagram above, and tighten the adjuster nut until it is tight before closing the QR lever.

Drive Module Removal

If severe space restrictions exist, it is possible to save space and disassemble the Mountain Trike into its three main sub-assemblies or modules.

The lever operated drive system on the Mountain Trike requires that the entire drive module is removed as a single piece including the wheel, drive system, suspension, lever and the brake. Please take a moment to familiarize yourself with the features and part names of the Trike to prepare for the following section. If the drive module also controls the steering, as shown in the diagram below, the rear wheel steering cable attachment will also need to be removed.

Right Drive Module (with Rear Wheel Steering Cable Attachment)

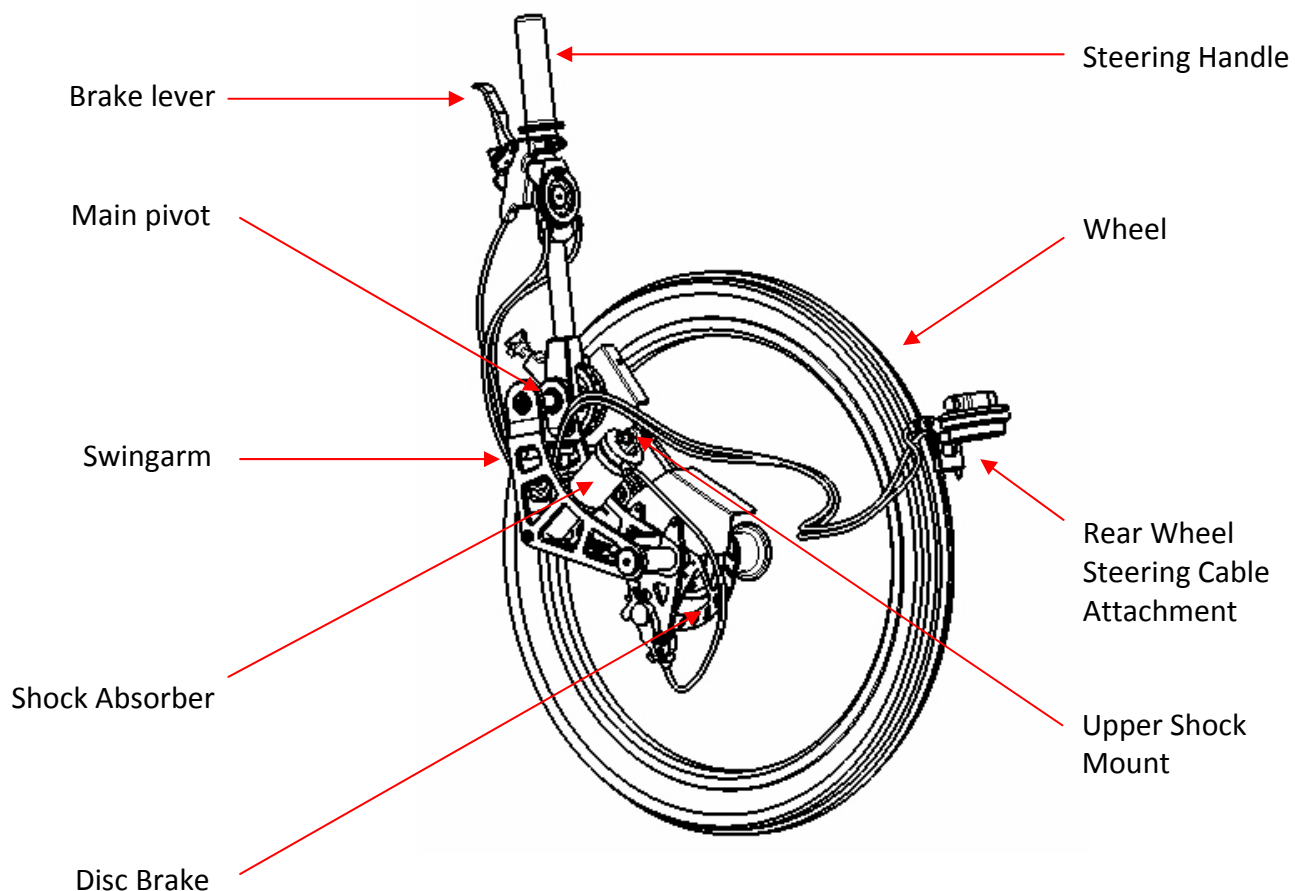

Each drive module is attached using a four bolt clamp at the main pivot and a single bolt through the upper shock mount, shown (upside down) below and labelled in the previous diagram. These bolts are removed using the 5mm allen key provided.

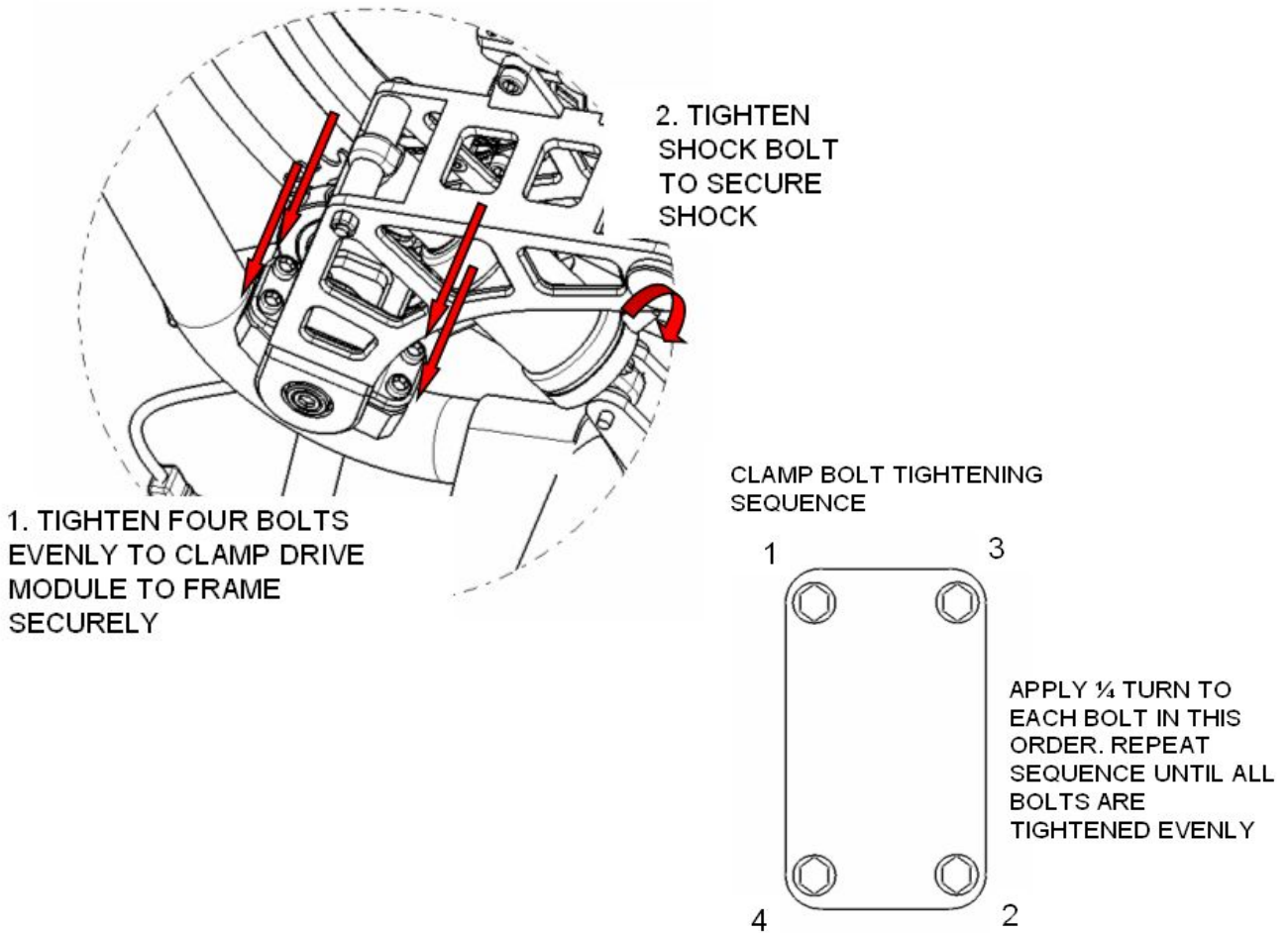

The Drive Module is held in place by the four bolts clamping the main pivot. The amount of clamping force is controlled by the torque on the bolts so it is important to ensure the bolts are tightened evenly and in sequence to avoid damage to the clamp and to ensure the module is attached securely.

The recommended torque for the clamp bolts is **8-9Nm (70-80 in-lb)**.

⚠ WARNING - It is important that the Clamp Bolts are tightened correctly such that they apply the right compression force. Failure to do so could result in a drive module becoming loose and in a worst case scenario, detaching during a ride causing the rider to lose control and fall.

⚠ CAUTION - Always take care when installing or taking out the Clamp Bolts in order to avoid potential pinching or crushing of your hands in the clamping zones.

Removal of Rear Wheel Steering Cable Attachment

When attaching or removing the Drive Modules, consideration must be given to the connection of the two steering cables to the rear wheel. The Steering Cable Attachment must be removed with the Drive Module by pressing the spring loaded button that engages the Steering Cable Attachment onto the rear wheel fork. Once the button on the side is depressed the Steering Cable Attachment lifts off and can be stowed with the Drive Module.

STEERING DISENGAGEMENT

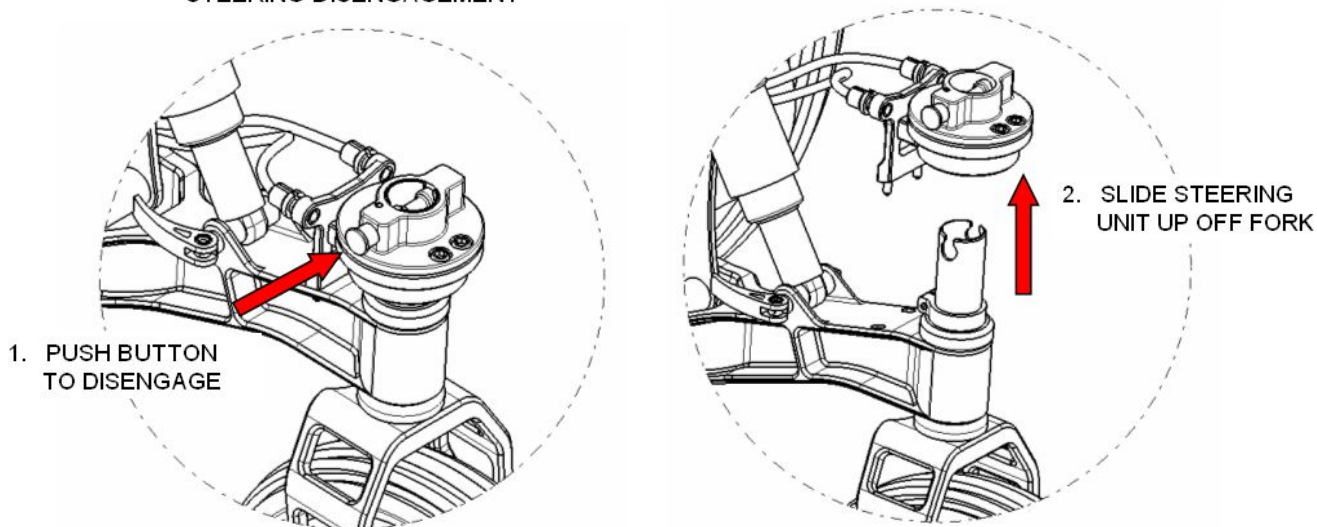

Footrest and Anti-tip Wheel Adjustment

The footrest and anti-tip wheels can be raised, lowered or removed by pulling the spring loaded pins located behind the front legs of the frame and moving the footrest to the desired position.

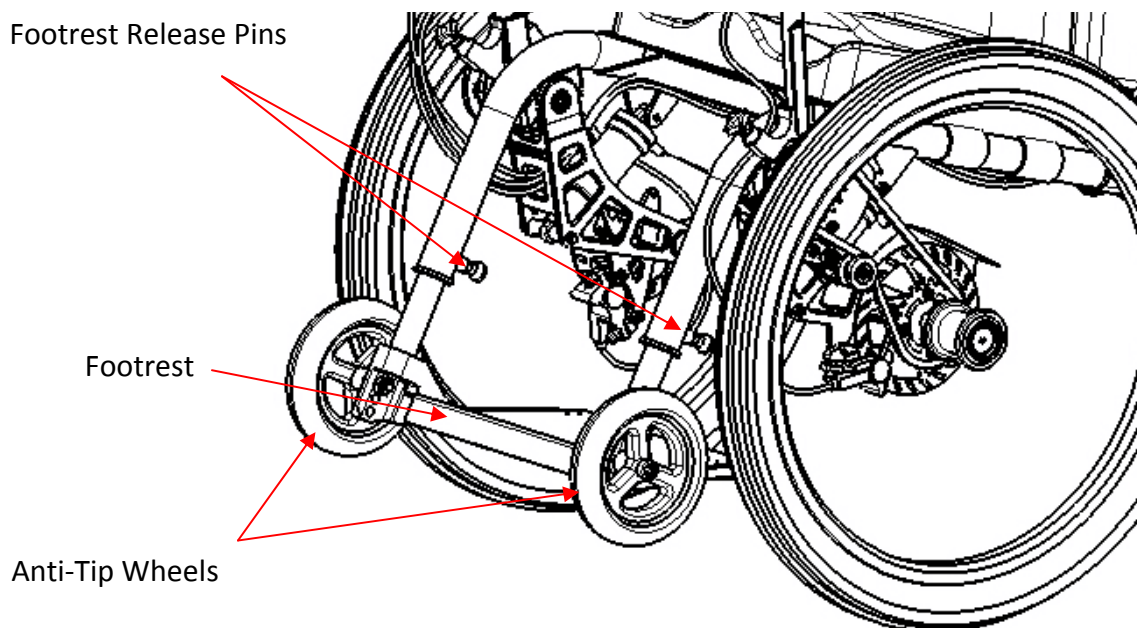

2.0 Riding Instructions

The method of using a Mountain Trike is quite unlike any other wheelchair you may have used before. The propulsion and control systems are designed to be simple to use and intuitive and give the rider unsurpassed levels for ride and handling performance. However, it may take a few moments to become familiar with the controls upon your first try.

Please choose a smooth and level piece of ground that is clear of obstructions and contains sufficient space when riding your Trike for the first time.

Areas that contain rough or steep terrain, open water, manoeuvring vehicles or large amounts of pedestrian traffic are not recommended.

Note: Always keep at least one or two fingers resting on the brakes at all times when riding and lean into the corners as you turn, lean left when turning left, lean right when turning right.

2.1 Pre-Ride Mechanical Safety Checks

Before riding your Mountain Trike, it is imperative that you make the appropriate safety checks to ensure that the Trike is fit to ride.

- First make sure that the modules are correctly attached, the Drive Module Clamp Bolts are tight and all the QR levers are closed tight. Pay close attention to the drive module Clamp Bolts and the rear shock absorber QR lever.
- Make sure the Rear Wheel Steering Cable Attachment is correctly attached and centred, and the steering cables are secured correctly.
- Check both locking pins on the seat back are engaged and the seat is not free to swing or fold.
- Ensure that footrest locking pins are correctly engaged so that it is not free to move.

Make a thorough visual inspection for damaged parts or any sections that show excessive wear or exhibit unintended movement or looseness.

- Check all of the bolts that connect the parts of the Trike together. For advice on tightening bolts see maintenance Section 3: 'Service'.
- Check the spokes of the wheels, they should all be of uniform tension and none of the spokes or adjusting nipples should be loose. For advice checking wheel spokes see maintenance Section 4: 'Service'
- Check for unintended movement in the wheel bearings by lifting each wheel off the ground slightly, and holding the top of the wheel, try to wiggle it side to side. There should be no sideways movement or knocking felt.

- Do the same at the rear wheel. Ensure there is no unintended movement in either the rear wheel bearings or the steering bearings.
- Check the drive levers for sideways unintended movement.
- Check the Drive Module chains, they should be tight with no slack or sagging evident.
- Check the operation of the brakes and steering.
- Check Hydraulic brake hose for physical damage and leakage. If the hose is damaged do not ride your Mountain Trike until it has been repaired by your Mountain Trike dealer

If the wheels, Steering Handle, rear wheel steering cable attachment or drive lever bearings appear loose, or if you discover that anything is not as it should be, do not ride the Trike and consult your Mountain Trike dealer.

Suspension

There is an individual shock absorber for each wheel of the Trike. The shock absorber units have been factory set. (There are however several adjustments that can be made to suit personal preference). Your Mountain Trike dealer can help you set the suspension for you needs.

Tyre Pressure

Check that the tyre pressures are even and are suited to the terrain and the type of riding being undertaken. The range of acceptable tyre pressures is printed on the tyre, depending on the manufacturer's specification. Recommended tyre pressures for different riding conditions:

- | | | |
|------------------------------|-------------|-------------------|
| • Wet mud, wet grass, gravel | 20 - 25 psi | (1.38 - 1.72 bar) |
| • Dry dirt, dry grass | 25 - 35 psi | (1.72 - 2.41 bar) |
| • Wet street | 30 - 35 psi | (2.07 - 2.41 bar) |
| • Dry street | 35 - 40 psi | (2.41 - 2.76 bar) |

 **WARNING** - Failure to ride with the appropriate tyre pressures can increase the risk of punctures, damage to the Trike or could possibly cause the rider to lose control and fall.

2.2 Transferring in and out

Due to the presence of the extra features and systems on a Mountain Trike, special care must be taken whilst transferring in and out. Whilst every effort has been made to make the transfer as straight forward as possible, some extra consideration should be made before first attempting to transfer.

Choose a piece of smooth, flat ground to perform the transfer with sufficient space to use transfer aids if necessary and allow assistance if required.

Ensure the parking brakes are applied on both drive levers, one on each side, to stop the Mountain Trike moving during transfer.

PARKING BRAKE APPLICATION

1. PULL BRAKE LEVER TO APPLY DISC BRAKE

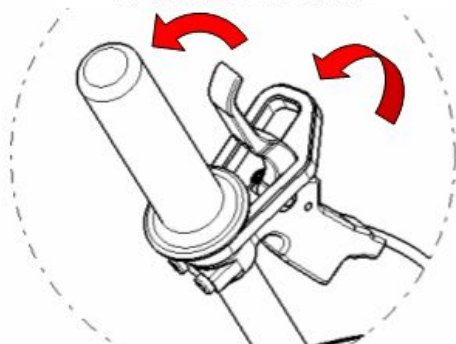

2. ROTATE PLATE TO LOCK LEVER IN POSITION

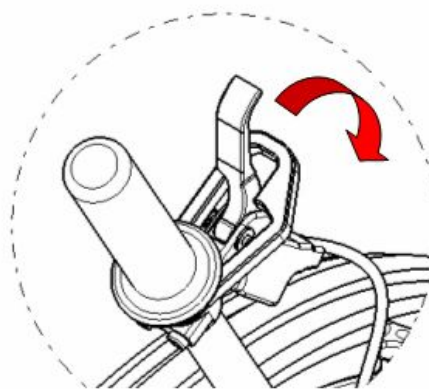

3. TO UNLOCK BRAKE, ROTATE PLATE BACK TO CENTRE POSITION SO BRAKE LEVER IS FREE TO MOVE

Ensure that the drive levers are laid down in the back position and are not obstructing the transfer in and out of the Mountain Trike. You may also wish to lift up the footrest to allow you to get closer to the front of the Trike.

FOLDING FOOTREST

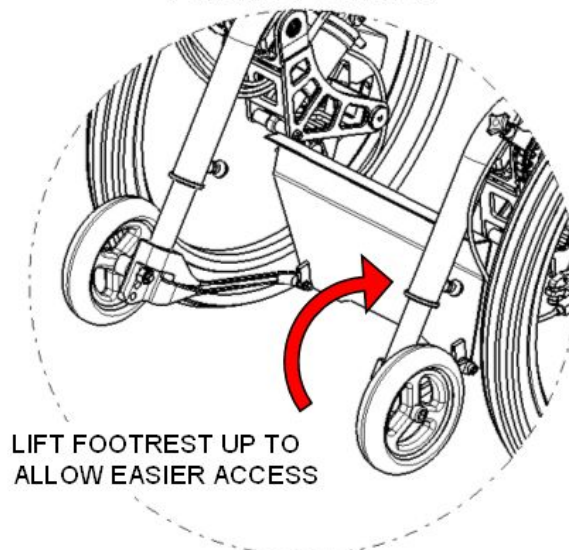

LIFT FOOTREST UP TO ALLOW EASIER ACCESS

Take a moment to decide the best approach when transferring. It may not be possible to use the method you would normally use transferring chair to chair, so make sure you're comfortable with any approach before an attempt is made.



CAUTION - Contact with the high performance, off road tyres can cause abrasion to skin and clothing during transfer. If a side-on transfer is attempted, ensure the tyres are covered or that sufficient clearance can be guaranteed before any attempt is made.

Your Mountain Trike dealer can advise you on recommended modes of transfer, however, the method and the approach taken is down to the individual. Please take a moment to determine the best method for you.

2.3 How to Engage / Disengage Drive

When transferring, it is best to have the drive levers disengaged, laid down in the back position and the parking brake is applied to prevent any unexpected movement. To disengage the drive, pull out the engagement handle and twist 90 degrees to lock it in its disengaged position. Once you have transferred and are happy in the Mountain Trike, it is time to engage the drive levers and release the parking brake, ready to propel the Trike.

Each drive lever engages separately. When disengaged, the drive levers are totally decoupled from the drive system and the levers are free to move until they hit their end stops. Similarly, the wheels are free to roll if unobstructed. To engage the drive, keep the parking brake on, and engage one lever at a time. Do not release the parking brake until drive is engaged and you are ready to ride off.

Take up the left lever, and with the lever positioned slightly forward of upright centre, twist the engagement handle and push the drive lever forwards until the Engagement Handle springs downwards and the pin seats into one of the holes in the Drive Ring. The left drive lever should now stay up and ready, leaning slightly forward. Repeat for the right hand side. The drive levers are now engaged and ready to use. Ensure the Engagement Handle is fully down and securely engaged before proceeding.

Once drive is engaged, release the parking brakes on both sides and the Trike is free to be propelled by the rider.

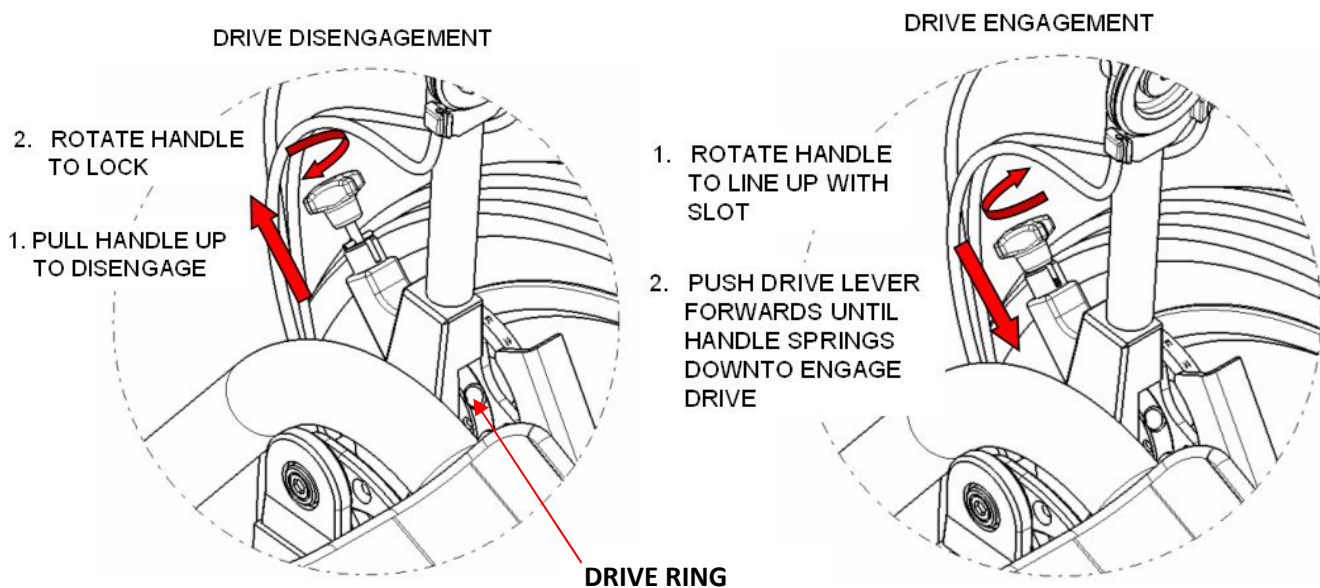

2.4 Forward Drive

The drive levers will propel the Trike forward by driving each of the two front wheels independently. Upon pushing the levers forward, the drive will engage, turning the wheels, resulting in forward motion. Upon pulling the levers back, the drive system allows the levers free motion to return before beginning another driving push. It is possible to push both levers together, alternate left and right or even to drive short distances one handed by only pushing the Steering Handle.

This system allows the Trike to coast forward too, such that you only push when you feel the need to.

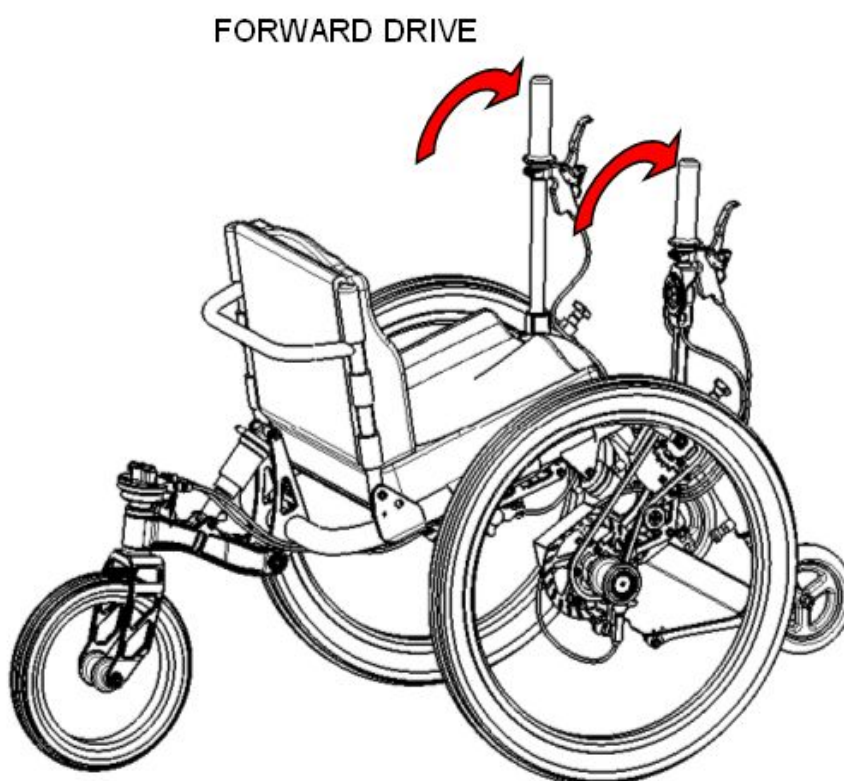

2.5 Reverse Drive

To move the Trike backwards when **on flat ground**, first ensure the steering is straight, disengage the drive on both levers and lay them in their resting position. Then push on the wheels, as if the Trike were a standard wheelchair, to propel backwards.

If reversing **down a slope**, ensure the steering is straight and apply the parking brakes. Then disengage the drive on both levers and whilst holding the brakes firmly on, release the parking brakes and gently release the brake levers to roll backwards in a slow and controlled manner.



CAUTION - Reversing can be difficult, only reverse the minimum amount required and then drive forwards turning to move away from the obstacle in a forward direction.

2.6 Steering

Steering is achieved by pointing the steering handle in the direction that you want to go, turn it left to go left and right to go right. This turns the rear wheel like the rudder of a boat. Sounds simple? It is, but it can take a few moments to get used to.

Pointing the Steering Handle left or right changes the angle of the rear wheel, affecting a turn. The Steering Handle position dictates the position of the rear wheel at all times, so bear this in mind. If the Steering Handle isn't straight, i.e. in line with the rest of the drive lever, you won't go in a straight line.

Like many vehicles, any steering input must be combined with speed or drive to affect a turn. You will often need to push one or both of the drive levers whilst pointing and holding the Steering Handle in the desired direction. This can take some practice before it becomes smooth.

It is also recommended to practice turning and get a feel for the turning circle of the Trike in a flat and smooth area that's free of obstructions before moving onto more challenging terrain or busy or confined spaces.

It is important to consider your speed when attempting turns. At low speed, tight turns with the handle at 'full lock' are possible allowing the Trike to turn in its own width. However at higher speeds, it is best only to make gradual turns with small amounts of steering lock as sudden tight turns at speed increase the risk that you may lose control and fall.

STEERING

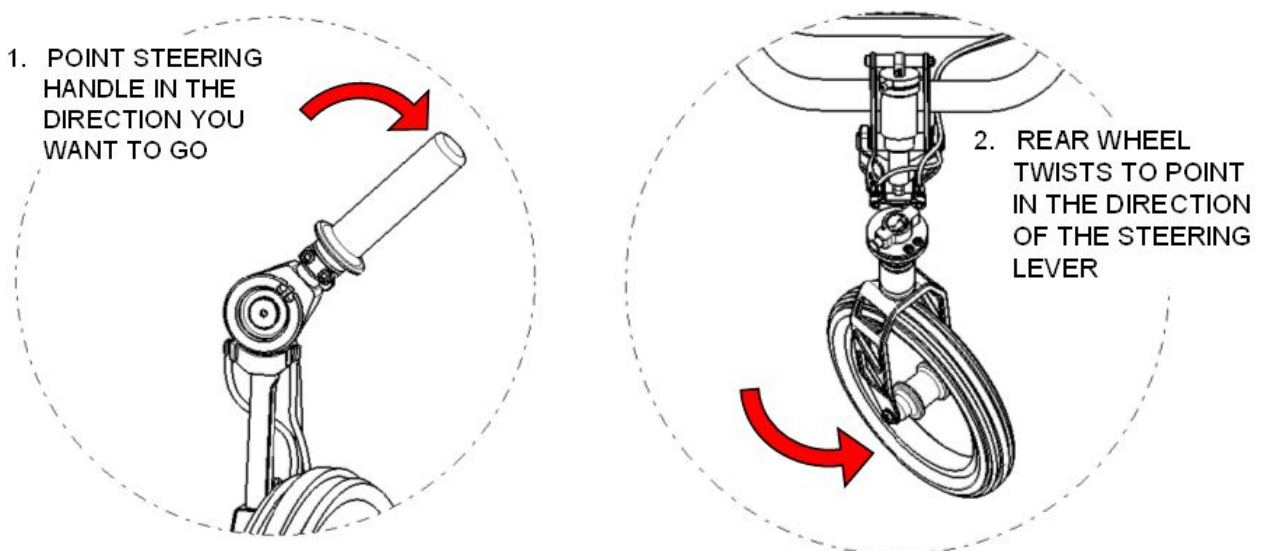

CAUTION - The steering is sensitive, be careful not to over steer, modify your speed with the tightness of the turn and always lean into the turn, leaning left to turn left and leaning right to go right.

2.7 Braking

Mountain Trikes come equipped with two high specification mountain bike hydraulic disc brakes. These provide an unsurpassed level of braking power and control. The brakes work on the two driven wheels and are available in either *independent* (meaning that each wheel has its own brake lever) or *combined* (meaning a single brake lever operates both wheels at the same time).

Only very gentle pressure on the brake lever is required to begin braking. There is enough power in the brakes to control speed whilst descending and hold the Trike still on slopes whilst ascending. To provide small amounts of braking force to check speed, only gentle pressure is required. For independent brakes it is also important to apply force evenly to each brake lever so that each wheel is experiencing the same amount of force, otherwise you could veer to the side.

Again, use smooth, flat and open ground to practice braking and get a feel for the brakes and making controlled stops before attempting more challenging terrain.

Note: Always keep at least one or two fingers resting on the brakes at all times when riding.



WARNING - Excessive braking force could cause the Trike to tip causing the rider to lose control and fall.



WARNING - Uneven force applied to each brake when using independent brakes can cause the Trike to change direction causing the rider to lose control and fall.

Anti-tip wheels

The anti-tip wheels at the front of the Mountain Trike are designed to prevent the rider from tipping too far forward and falling out when applying the brakes. The use of the optional seat belt may help riders feel more secure in the event of tipping.

2.8 Hill and Kerb Climbing

The features of the Trike allow the rider to climb slopes that would be very difficult to climb in any other wheelchair. Climbing can be thought of as an advanced riding technique and should only be attempted once a good level of all round control has been achieved.

Before attempting to climb any surface, check thoroughly that it will be possible to get back down safely.

It is recommended that the climbing technique is practiced on flat or very gently inclined surfaces before climbing any steeper terrain.

To begin climbing, position the Trike to approach the climb head on, rather than attempt to traverse at an angle – this can cause loss of traction.

Once ready at the foot of the climb, make a smooth, even forward push on the drive levers, both levers at the same time. Once the levers are pushed forward as far as is comfortable, apply both brakes firmly. With the brakes still applied, pull the levers back, again, only as far as is comfortable. With the brakes still applied, put a small amount of forward pressure on the drive levers until you feel the resistance of the brakes, then gently remove pressure from the brake levers and push through with the drive levers to continue climbing. Once the Trike has reached a standstill, re-apply the brakes, pull the drive levers back and push again.

Continue this action of pushing, braking and pulling back, then pushing again, until you have crested the slope. If enough forward momentum is achieved between pushes, it may not be necessary to apply the brakes.

You will notice that it takes very little effort to hold the Trike still on the brakes while pulling the drive levers back. You can wait as long as you need to between pushes, provided the brakes are still applied.



WARNING - Riding on steep terrain can be unforgiving and increases the risk of the rider losing control and falling.



CAUTION - When climbing a kerb or similar obstacle always approach it head on and ensure that the steering is straight until the **rear wheel** has successfully traversed the obstacle. Turning before the rear wheel has passed up and over the obstacle may result in you becoming stuck.

2.9 Descending Slopes

Descending requires the use of the steering and braking systems, but can also require input from the drive system.

It is extremely important to check the suitability of any terrain considered for descending before attempting to ride it. If for any reason you are unsure, do not ride it, find an alternative way round.

The most important aspect of descending is using the brakes to control speed. Feathering or 'Modulating' the brakes, using finely controlled pressure on the brake lever is required to keep the wheels rolling whilst providing the required braking force to maintain controllable speed. Too little braking force and speed will increase until control is lost, too much braking force can cause tipping which could lead to a fall.

Whilst descending, it will often be necessary to use the Steering Handle to make adjustments to your course as you go. This can be one of the most enjoyable aspects of riding the Trike. No braking is required to steer the Trike. Rather, the braking system is used to control the speed of a descent, and the steering system is used to control the direction. Both of these techniques must be practiced and the rider must be confident doing both concurrently before any attempt at descending is made.

The anti-tip wheels on the footrest limit the forwards tip of the Trike should the brakes be applied too sharply, or if the gradient is too steep. However, it is always recommended to keep the rear wheel in contact with the ground to provide optimal control, so avoid prolonged descending while balanced on the anti tip wheels.

3.0 Safety Advice

Please read this section carefully, the amount of detail may seem excessive or appear to be stating pure common sense, but the Mountain Trike Company is committed to ensuring its rider's are as safe as possible so they gain the maximum enjoyment from riding their Mountain Trike.

Seat Belt and Foot Straps

A seat belt and foot strap is also provided with your Mountain Trike as an optional extra should you so wish to use them. The seat belt can be attached at the fastening points either side of the bottom of the seat back and the foot strap can be attached between the two forward legs of the Mountain Trike frame.

3.1 Riding safely Off Road

All riders should exercise their own judgement as to whether the area they are travelling requires them to need assistance and take a capable companion if necessary. Children should be accompanied by a responsible adult when travelling Off Road.

1. Off road terrain can feature variable conditions and hazards, so stay alert and ride within your abilities.

Follow the advice in our Operation section and build up your skill gradually on easy terrain before attempting more challenging ground

2. We recommend you wear appropriate clothing and an approved bicycle helmet
3. We recommend you don't ride alone in remote areas.
4. We recommend the you take a mobile phone, money, additional clothing, food and drink, tools, puncture kit etc and always tell someone where you are going and when you expect to be back



5. Observe the Countryside Code with regards to other people and animals, give way to them
6. We do not recommend you do stunts, tricks, jumps etc, please think carefully about your skills, read section 3.5, and accept that this type of riding has associated higher risks.

3.2 Riding safely about town

You may wish to ride your Trike around town, over uneven pavements, cobbled streets or inside buildings.

1. Avoid riding in the road as this can be highly dangerous, always stay on the pavement where possible
2. Obey all Rules of the Road and all local traffic laws
3. Respect other people and observe rights of way
4. Beware that others may not see you coming
5. Be prepared to avoid obstacles and look ahead for
 - Vehicles slowing or turning, entering the road or your lane ahead of you, or coming up behind you.
 - Parked car doors opening.
 - Pedestrians
 - Children or pets playing nearby.
 - Narrow gaps or spaces
 - Kerbs, pot holes, drain covers, railway tracks, expansion joints, construction works, debris and other obstructions that could cause you to swerve into the path of others, or hinder your progress
6. Slow down and look both ways at street crossings
7. Never ride with headphones as they can drown out noises from potential hazards around you, or the cables may tangle in the moving parts of the Trike
8. Never carry a passenger as this could make the Trike unstable
9. Take care when carrying luggage, always ensure it is strapped properly to the Trike and cannot become tangled in moving parts
10. Although it may be tempting on a long hill climb (!) never hold on to another vehicle to tow you along
11. Do not do stunts, jumps or other tricks, this may endanger your safety and the safety of those around you
12. Don't weave through traffic or make any moves that may surprise people
13. Never ride your Trike when under the influence of alcohol or inhibiting drugs.
14. Take care when riding in bad weather conditions, when visibility is obscured, at dawn, dusk or in the dark, or if you are very tired. These conditions have associated higher risks.

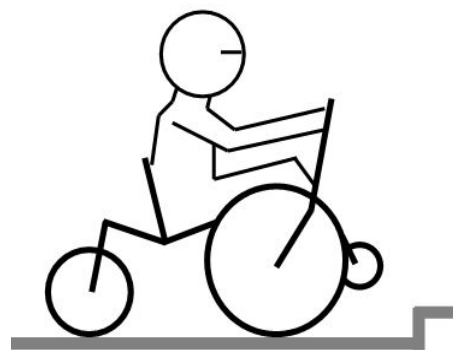

3.3 Wet and Cold Weather Riding

1. Wet weather reduces grip for steering, braking and drive, therefore the risk of an accident is dramatically increased in wet conditions.
2. Avoid excessive speed and allow greater stopping distances and apply the brakes gently to avoid skidding.
3. Take care when crossing soft wet ground, if in doubt; avoid extremely boggy ground which may result in the Trike becoming stuck.
4. Take care when riding over snow or ice as the ground may be slippery, reducing the effectiveness of the brakes and steering.



3.4 Night Riding

Your Mountain Trike does not come supplied with lights or approved reflectors.

1. Night riding presents increased risk over riding in the day as visibility is reduced.
2. Ride more slowly as the lower visibility will reduce the time available for you to react to hazards. Expect the unexpected!
3. Conditions can also be colder at night, so ensure you take enough warm clothes



3.5 Extreme riding

Although the Trike is designed to cope with some highly challenging terrain, there are of course limits to what terrain, obstacles and manoeuvres are possible. We do not recommend extreme riding. If you choose to take part in extreme riding, you voluntarily assume a greatly increased level of risk that you may get hurt and ultimately should accept responsibility for the consequences.

Extreme riding can be roughly quantified as:

- Riding downhill over very rough ground
- Riding downhill at high speeds



- Attempting jumps or drops and becoming airborne
- Attempting tricks or stunts such as nose wheelies or sudden spins
- Tackling obstacles such as flights of stairs
- Riding through deep water
- Steep hill climbing (which may result in you becoming stuck and needing to reverse back down)

If you choose to take part in these activities, there are measures you can take to reduce the level of risk. However, even if you follow these measures, there is still sufficient risk present that could cause injury to yourself.

- Take advice from experienced riders on conditions and riding techniques
- Wear appropriate safety clothing and an approved bicycle helmet
- Build you capability up gradually by riding easier terrain first before attempting more challenging obstacles
- Understand that the stresses put on the Trike with these activities may break or damage parts and void the warranty



WARNING - Although some catalogues, advertisements, articles and videos about Mountain Trike riding may depict riders engaged in extreme riding, this activity is extremely dangerous, and increases your risk of injury or death. Note that the actions shown are being performed by highly experienced professionals. Know your limits and always wear a helmet and other appropriate safety gear. Even with state-of-the-art protective safety gear, you could be seriously injured when jumping, stunt riding or riding downhill at speed.





WARNING - All Mountain Trikes have limits in terms of their strength and extreme riding can exceed those limits.

3.6 Adding Accessories and Changing Components

Many of the components on the Mountain Trike are standard mountain bike parts which may be changed if you wish. However, changing components is done so at your own risk as they may not have been tested by the manufacturer for compatibility or performance. Consult your dealer before changing any components.

Only use approved accessories and parts. Follow the associated instructions when installing them. Please consult your Mountain Trike dealer as some parts can only be fitted by a qualified technician or if you require any other assistance with fitting accessories.

 **WARNING** - Failure to confirm compatibility, properly install, operate and maintain any component or accessory can compromise safety causing the User to lose control and fall.

 **WARNING** - Fitting components or parts to your Trike which are not Mountain Trike approved replacements may compromise your safety and may void the warranty. Check with your dealer before changing any components on your Trike.



4.0 Service

The Mountain Trike is a highly technical piece of equipment and must be maintained and serviced appropriately to provide the required service life and safe operating performance. The Mountain Trike shares many features and systems of high specification mountain bikes and the maintenance and service regimes are therefore similar.

Due to the potential safety risks of operating a badly maintained Trike, it is recommended that you consult your Mountain Trike dealer for all your maintenance needs and servicing, and follow the recommended maintenance schedule, shown in 4.2. However, some maintenance can and should be performed by the user and requires no special tools.

Following the bedding in period, discussed in 4.3, the Mountain Trike Company recommends a complete service by the Mountain Trike dealer every 6 months or 50 hours of riding, whichever comes sooner, or if any fault is suspected.

4.1 Looking After Your Mountain Trike

To keep the Trike running at peak performance and to ensure the longest possible service life, after every long ride, or if ever the Trike is exposed to water, mud and grit, the following service checks and actions should be made. If you are in any doubt about performing a service task yourself, you must consult your Mountain Trike dealer before attempting the task or riding the Mountain Trike.

General cleaning is recommended after every ride. Warm water with a small amount of detergent is sufficient to remove most dirt. Be careful to avoid excessive amounts of water entering the drive, braking or steering systems. Refrain from using high pressure washing systems as these can penetrate sealed parts, reducing life. Once cleaned, thoroughly dry the Trike, as if water is left to collect it can corrode moving parts.

Once clean, the following checks and maintenance should be performed with every ride.

Drive

The chains that transfer drive from the drive lever to the wheels require cleaning and lubricating with appropriate bicycle chain lubricant to ensure long life and smooth running. See maintenance and lubrication checklist.

If you are in any doubt about performing a service task yourself, you must consult your Mountain Trike dealer before attempting the task or riding the Mountain Trike.

Warning - The chain drive area carries the risk of trapping and pinching fingers and hands. Be extremely careful while accessing the chain drives to avoid pinch points.

Warning - The braking systems must be kept clean and free from contamination. If lubricant is allowed to come into contact with any part of the braking system, it can cause failure which could lead to loss of control and a fall. Once brake pads are contaminated with lubricant they must be replaced with new ones and the rotors cleaned thoroughly with isopropyl alcohol or disc brake degreaser.

Check the tension in the chain and the operation of the Chain Tensioners. If the chain is at all slack, seek the advice of your Mountain Trike Dealer.

Lift each wheel clear off the ground and check for looseness or unintended movement left to right. The wheel should feel totally solid relative to the frame and drive swing arm. Similarly, check the entire drive module for unintended movement relative to the frame. If the bolts that secure the swing arm are tight, and any unintended movement is felt, seek the advice of your Mountain Trike dealer, as they may need to replace the shock absorber bushings, requiring the work of a

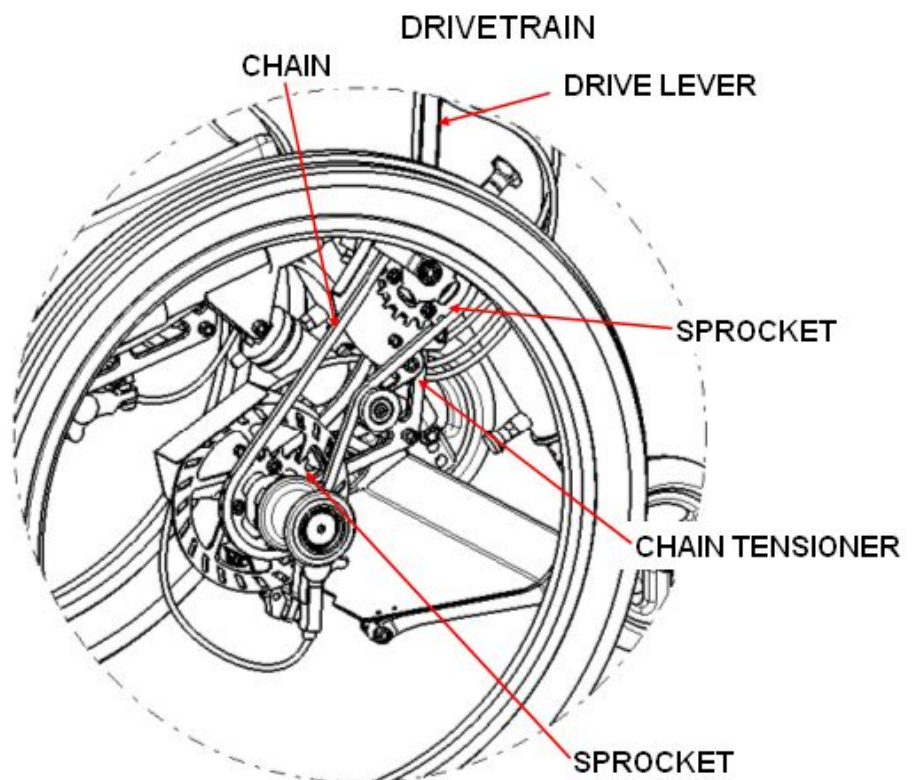

qualified technician.

Again, with the wheel clear of the ground and free to spin, check the wheel spins freely and true without resistance or wobbling.

On each wheel, check the rims for damage or dents. Take a pair of spokes between fingers and thumb and squeeze together, they should feel tight and each pair should feel roughly equal. If there is any rim damage or significantly loose spokes, seek the advice of your Mountain Trike dealer as they may need to re-tension the spokes or rebuild the wheel.

Check the tyres for any cuts, damage, excessive tread wear or embedded objects. If any damage is found, the tyres should be replaced.

Check the suspension is operating correctly by pushing down on the seat or frame, the shock absorbers should move smoothly. If the shock absorbers do not move freely, or appear to be seized seek the advice of your Mountain Trike dealer as the shocks are an item requiring specialist knowledge and tools to service.

Check the drive levers for looseness or play and check the drive engagement for smooth operation. If the levers are loose or the drives are hard to engage/disengage, seek the advice of your Mountain Trike dealer

Brakes

Pull each brake lever. It should swing smoothly and there should be a distinct 'bite point' at which the pads contact the disc. If the brake lever is rough, the bite point feels spongy or there is a reduction in braking power, seek the advice of your Mountain Trike dealer as the brakes require specialist knowledge and tools to service.



Warning - Hydraulic brakes contain fluid which is hazardous to health if ingested and irritates skin on contact. The Mountain Trike company recommend any maintenance or service to the brakes themselves is carried out by your Mountain Trike dealer. If a brake fluid leak is suspected, seek the advice of your Mountain Trike dealer



Warning - Hydraulic disc brake systems are sensitive to temperature. If the brake systems experience prolonged exposure to intense, direct sunlight, the fluid can expand, locking the brakes and potentially damaging the internal seals. If high surface temperature exposure is suspected, contact your Mountain Trike dealer.

Steering

Swing the Steering Handle from side to side, it should feel smooth and positive without looseness or backlash. With your hand, squeeze the two steering cables together at the Steering Unit. There should be little or no slack in the cables to ensure good steering response. If looseness is felt, the cables will need adjusting on the barrel adjusters at each end, or by pulling more cable through the clamp.

If the motion of the Steering Handle feels rough or it takes excessive force to move the lever, the cables could be frayed or damaged and will need replacing.

Check the Steering Handle for play at the pivot joint, if there is looseness in the forwards/backwards direction, check the nut is tight and seek the advice of your Mountain Trike dealer if the looseness persists.

Check the position of the Steering Handle corresponds to the correct position of the rear wheel. When the lever is straight and upright, the rear wheel should point straight forward. At full lock in either direction, the wheel should be close to 90 degrees to the forward direction. If the wheel is not straight corresponding to the lever, the cables must be adjusted.

Check the operation of the Steering Unit engage and disengage system. The module should release easily and once engaged, be attached solidly with no looseness. If engaging or disengaging is difficult, or the Steering Unit is loose when engaged, seek the advice of your Mountain Trike dealer



WARNING - Never ride your Mountain Trike if the steering cables are loose as this can result in poor steering response which could cause you to lose control and fall.

Frame and Seat

Check the overall condition of the frame for cracks, dents and other damage. If the frame is suspected of having any damage at all, seek the advice of your Mountain Trike dealer.

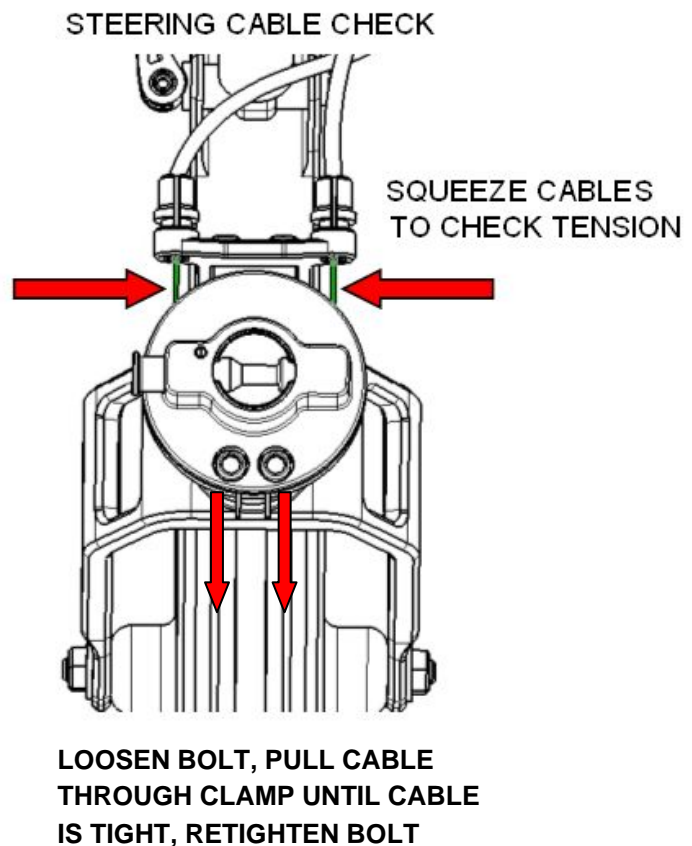

Check the seat for tears or lesions, if the seat is damaged or not functioning correctly, it should be replaced. Although the seat material passes the relevant fire retardant standards, care should still be taken to avoid open flames or exposure to high temperatures.

In the case of a crash or fall, thoroughly check the Mountain Trike for any damage. Following a crash, always report to your Mountain Trike dealer for a full check up before riding again. Never ride your Mountain Trike unless you are completely confident that it is in full working order.

4.2 Maintenance Schedule

1. Lubricate chain using appropriate lubricant after every 5 - 6 hours of use or after each ride if conditions are especially wet or dry.
2. The ends of the steering cables should be lubricated after every 5 - 6 hours of use or after each ride if conditions are wet. If the steering feels stiff after lubrication, the cables may need replacing by your Mountain Trike dealer.
3. To service bearings, special tools are necessary, only your Mountain Trike dealer should do this. Wheel, drive train and pivot bearings should be serviced every 12 - 18 months or when looseness is felt in the bearing.

4.3 Bedding in Period

When first riding the Trike from new, it is important to understand that various components and systems will be 'bedding in' and will take time to reach their full operating performance. As every rider will use their Trike differently, the bedding in period will vary from person to person. Typically this may occur after the first 30 days of use or earlier if ridden hard for 3 – 5 hours. Section 1.3 'The Mechanical Safety Check' section provides an excellent guide to what areas to check for signs of looseness or unintended movement in the systems. It is important to perform these checks before and after each ride.

- Steering cables can stretch producing looseness in the steering system, see the section on steering in 4.1 for advice on how to check and adjust the cables.
- The spokes in the wheels can sometimes stretch, requiring the wheels to be serviced by a capable bicycle technician.
- The interface between the brake pads and the discs take time to bed in, such that the brakes won't work at their full power straight away.

Your Trike will last longer and serve you better if you observe the initial bedding in period and ride gently and cautiously before riding hard on challenging terrain.

5.0 Warranty

Thank you for choosing a Mountain Trike. We are sure you will have many years of enjoyment from your new purchase. Your warranty was automatically registered to you when you bought the Mountain Trike. Keep your receipt safe and you may wish to take a moment to write down your date of purchase, dealer details and Trike ID number on page 3 of this manual for your own records.

A Note about Warranty Claims:

If you suspect you have reason to make a warranty claim, it is important to follow the proper procedure. The first thing to do is immediately contact the Mountain Trike dealer from whom you purchased your Mountain Trike. They will be able to assist you with the claim and answer any queries you may have.

THE MOUNTAIN TRIKE COMPANY LIMITED WARRANTY

The Mountain Trike Company Ltd warrants each Mountain Trike frame and Mountain Trike manufactured parts for 3 years from the purchase date of the original owner.

Warranty claims for all non Mountain Trike Company manufactured components, including shock absorbers, disc brakes, brake levers, wheels etc... should be sent to the representative of the respective manufacturer via the Mountain Trike dealer.

This warranty is limited to the repair or replacement of a defective frame or components and is the sole remedy of the warranty and applies only to a Mountain Trike purchased from an authorised Mountain Trike dealer.

The warranty does not cover normal wear and tear, improper assembly (such as crossed clamp bolt threads), poor maintenance or installation of parts and accessories not originally intended for, or compatible with the Mountain Trike - Specifically the fitting or modification of suspension units or brakes not supplied as original equipment.

The Mountain Trike Company reserve the right not to warranty Mountain Trikes, frames or components which in their opinion have been used for riding conditions outside the limits of the product. These limits are described in the Owner's Manual Section 3.5. Your Mountain Trike dealer can provide clarification of these categories and the intended use for the Mountain Trike.

Use of the Mountain Trike in competitive events, trick riding, ramp riding, jumping, aggressive riding, riding on severe terrain, riding in severe climates, riding with heavy loads, commercial activities and other types of non standard use can dramatically shorten the useful product life cycle of Mountain Trike and may result in an unpredictable failure of a Mountain Trike that would not be covered by this warranty.

The warranty does not apply to damage or failure due to accident, abuse, collision, impact or neglect.

The warranty excludes Mountain Trikes used for competition, speed or time trials, hire, reward or rental.

The Mountain Trike Company Limited shall not be responsible for incidental or consequential damages.

Claims under this warranty are to be made through an authorised Mountain Trike dealer. The complete Mountain Trike must be returned at owner's expense via the authorised Mountain Trike dealer to allow inspection of all the components and parts. Proof of purchase is required before warranty claims can be processed.

This warranty does not take the place of any legal and contractual rights between the Mountain Trike dealer and the owner. In the event of a problem the owner should contact the Mountain Trike dealer in the first instance.

All Mountain Trikes should be checked before every ride and periodically checked by an authorised Mountain Trike dealer, for indicators of stress and/or potential failure, including cracks, deformation, corrosion, paint peeling, dents and any other indicators of potential problems, inappropriate use, or abuse. If any abnormality or indication of a problem is found the Mountain Trike should be returned to an authorised Mountain Trike dealer or to The Mountain Trike Company Ltd for further checks before being ridden again. These are important safety checks and very important to help prevent accidents, bodily injury to the rider and shortened useful product life cycle of a Mountain Trike.

IMPORTANT NOTE: This warranty applies only to the original owner and is not transferable.



The Mountain Trike Company
www.mountaintrike.co.uk